

SWELLTITE®

COMPOSITE BENTONITE WATERPROOFING SYSTEM

DESCRIPTION

SWELLTITE is a highly effective Waterproofing composite of sodium bentonite compound integrally bonded to a geomembrane liner. This composition combines the active waterproofing benefits of sodium bentonite with the strength and puncture resistance of a thick geomembrane liner.

SWELLTITE is a true advancement in waterproofing membrane technology. Unlike other membrane systems which require near-perfect installation, SWELLTITE's reactive bentonite compound can expand to seal installation imperfections or small punctures in the membrane. SWELLTITE is manufactured at a factory controlled thickness of 90 mils (0.090") assuring the specifier, contractor, and owner of consistent material application. This engineered composite consists of a white (heat reflective) 12-mil geomembrane liner and 78-mils of bentonite compound with a clear release film attached. SWELLTITE contains virtually zero VOC, can be installed in almost any weather condition to green concrete, and most importantly, has proven effective for more than 20 years.

SWELLTITE works by forming a monolithic membrane upon hydration with water. When wetted, unconfined bentonite can swell up to 15 times its dry volume. When confined under pressure the swell is controlled, forming a dense, impervious waterproofing membrane. The swelling action of the bentonite compound can seal small concrete cracks caused by ground settlement, concrete shrinkage, or seismic action; problems over which there is normally no control.

APPLICATIONS

SWELLTITE is designed for below-grade vertical and horizontal structural foundation surfaces, as well as, above grade splitslab construction. Typical belowgrade applications

include backfilled concrete walls, masonry block walls, earth-covered roofs, and tunnels. Typical above grade split-slab construction applications include plaza decks, parking decks, and balconies. Additionally, SWELLTITE can be used for interior split-slab applications for mechanical rooms, kitchens, and laboratory facilities. Applications may include structures under continuous or intermittent hydrostatic pressure.

INSTALLATION

General: Install SWELLTITE in strict accordance with the manufacturer's installation guidelines. Use accessory products as recommended. Install SWELLTITE with the bentonite compound directly against the surface to be waterproofed. For ease of handling, the sticky bentonite compound is covered with a siliconized release film that must be removed during installation. Schedule waterproofing material installation to permit prompt placement of backfill material or concrete. For applications not covered herein, contact CETCO for specific installation guidelines.

Storage: Store SWELLTITE and accessory products in a dry location protected from construction operations and weather. Protect materials from moisture, excessive temperatures and prolonged exposure to direct sunlight during storage. When storing materials outside at a job site, provide weather-proof covering, top and all sides (allow for adequate ventilation). Do not double stack pallets in storage or during shipment.

Preparatory Work: Structural concrete surfaces should be smooth and free of dirt, rock, debris, oil, grease, laitance, or other foreign materials. Remove form fins and other protrusions to match substrate surface. Completely fill any Form-tie holes, honeycombing, voids, and cracks with non-shrink cementitious grout, M-2000 or

BENTOSEAL. Concrete surfaces to receive M-2000 Liquid Flashing should be water cured a minimum of 7 days prior to application. Where possible, design horizontal concrete surfaces with proper slope to drain.

FOUNDATION WALL INSTALLATION

Before installing SWELLTITE membrane to foundation walls, prepare substrate, and detail all vertical inside corners, penetrations, and the footing/wall joint as follows:

Vertical Inside Corners: Install a 3/4" (19mm) thick, continuous fillet of BENTOSEAL® at all vertical inside corners.

Penetrations: Apply a 3/4" (18 mm) thick fillet of BENTOSEAL around base of penetrations. Extend BENTOSEAL a minimum of 6" (150 mm) outward from penetration 90-mils thick. After SWELLTITE membrane is installed, apply a counter flashing of BENTOSEAL at membrane edge around penetration.

Footing/Wall Joint: Install at footing/wall joint a continuous 3/4" (19mm) thick, 45° angle fillet of BENTOSEAL.

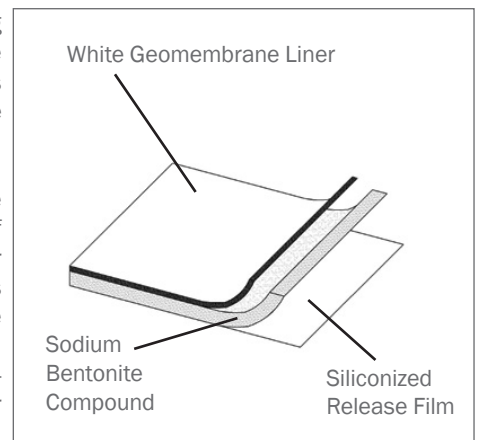

SWELLTITE COMPOSITE

SWELLTITE®

COMPOSITE BENTONITE WATERPROOFING SYSTEM

Membrane Installation: REMOVE CLEAR RELEASE FILM from back of membrane before installation. Starting at the base of the wall, install the membrane over the BENTOSEAL cant and onto the footing a minimum of 6" (150mm) with bentonite compound directly against the wall (white liner side toward installer). Secure all membrane edges with washer-head mechanical fasteners maximum 24" (600mm) on center or less as required to contour surface. SWELLTITE membrane may be installed either horizontally or vertically oriented. Overlap all membrane edges a minimum of 2" (50mm). Stagger membrane roll ends a minimum of 12" (300 mm). Seal all membrane overlap seams with CETCO Seamtape. Continue membrane installation to finished grade detail or as specified.

Cut membrane to closely fit around penetrations. Trowel a minimum 3/4" (19mm) thick layer of BENTOSEAL around penetrations. Extend BENTOSEAL onto penetration and completely fill area between membrane edge and penetration. Seal all overlap seams with CETCO Seamtape.

Terminate SWELLTITE membrane 12" (300mm) below finished grade elevation with washer-head fasteners maximum 12" (300mm) on center. Install GF-40SA flashing to primed concrete substrate with bottom edge overlapping top edge of SWELLTITE membrane minimum 4" (100mm). Overlap all roll ends a minimum 4" (100mm) to form a continuous flashing. Height of flashing shall be per project details and specifications. Install a rigid termination bar along top edge of GF-40SA; fastened maximum 12" (300mm) on center. Complete grade termination detail with tooled bead of CETSEAL along the top edge, at all penetrations through the flashing and all exposed overlap seams.

Backfill material should be placed and compacted to 85% Modified Proctor density immediately following the application of the membrane. If backfill cannot be applied immediately, protect membrane edges from precipitation with CETCO Seamtape. If backfill contains sharp or irregular material, cover membrane with CETCO approved protection material course to avoid damage during backfilling and compaction.

Tie into underslab waterproofing as required by overlapping the underslab waterproofing a minimum of 6" (150mm). When a drain tile is required, install it below the top of the footing.

Masonry Block Walls: CETCO recommends that the masonry block cells be filled with cementitious grout or concrete. All mortar joints should be completely filled and struck flush before membrane is installed to masonry walls.

HORIZONTAL DECK INSTALLATION

Before installing SWELLTITE membrane, prepare substrate and detail all drains, transition corners and penetrations. Consult manufacturer if deck is precast concrete planks or for other conditions not stated herein.

Drains: Trowel a minimum 90-mil (2.3mm) thick layer of M-2000 on the drain ring and continuing into the drains inward throat slope. Extend M-2000 a minimum of 6" (150mm) around the drain. Allow m-2000 to cure a minimum of 12 hours prior to installing membrane. After SWELLTITE membrane is installed around drain, apply a 60-mil thick counter flashing of M-2000 covering the membrane edge.

Penetrations: Trowel a minimum 3/4" (19mm) cant of M-2000 around the penetration. Extend M-2000 outward from penetration a minimum of 6" (150mm) at 90 mils thick. After membrane has been installed overlapping M-2000 2" (50mm), apply a 60-mil thick counter flashing of M-2000 at the membrane edge.

Transition Corners: Apply a 3/4" (19 mm) thick M-2000 fillet to inside transition corners. Then extend M-2000 at 90-mil minimum thickness for 6" (150mm) in both directions from the corner. Allow M-2000 to cure a minimum of 12 hours prior to installing membrane. After membrane has been installed to the corner, apply a 60-mil thick counter flashing of M-2000 covering the membrane edge.

Membrane Installation: REMOVE CLEAR RELEASE FILM from back of membrane before installation. Install membrane with bentonite compound directly against the deck (white liner side up) from the low point to the high point across the fall line to create a shingle-style installation. Overlap all membrane edges a minimum of 2" (50mm). Stagger membrane roll ends a minimum 12" (300mm). Seal all membrane overlap seams with CETCO SEAMTAPE.

Cut membrane to closely fit around penetrations overlapping previously installed M-2000. Trowel 90-mil thick counter flashing of M-2000 over membrane edge.

OPTIONAL ADHESIVE METHOD

Apply A-3000WB Adhesive by roller or sprayer at a rate of 250-275 sq ft per gallon (25sq m per 3.8 liters) and allow to cure (dry black) before applying membrane. After adhesive has cured, follow membrane installation instructions for applicable application, foundation wall or deck, excluding the mechanical fasteners. Primed surfaces not covered with membrane during the same working day must be re-primed.

SWELLTITE® COMPOSITE BENTONITE WATERPROOFING SYSTEM

SIZE PACKAGING

SWELLTITE roll size is 40" wide by 37' 9" long (1.02m x 11.5m); 125 square feet (11.5 sq m) per roll. Each roll weighs approximately 81 lbs. (36.8 kg).

LIMITATIONS

Do not install SWELLTITE in standing water or during precipitation. If ground water contains strong acids, alkalis, or is of a conductivity of 2,500 µmhos or greater, submit water samples to the manufacturer for compatibility testing.

SWELLTITE is not designed for unconfined above-grade waterproofing applications or subsurface applications that do not provide full confinement coverage. Do not install SWELLTITE on horizontal plaza deck applications that utilize pavers placed on pedestals.

SWELLTITE is not designed to waterproof expansion joints. Expansion joints require a properly engineered expansion joint sealant product manufactured by other companies. For foundation walls, backfill should consist

of compactible soils or crushed stone (3/4" or less). Compact soils to minimum 85% Modified Proctor density. Stone backfill larger than 3/4" (19mm) will require the use of a protection course; consult CETCO for specific guidelines. Avoid backfill with aggregate 1-1/2" (38mm) or larger. On horizontal decks, SWELLTITE requires proper containment from a topping ballast material.

SWELLTITE requires a minimum 3" (75mm) thick structural concrete slab or a minimum paver assembly weight of 20-lbs. (9kg) per square foot (includes sand or grout leveling course). When compactible soil topping is used, it must be at least 18" thick and compacted to a minimum 85% Modified Proctor density.

ACCESSORY PRODUCTS

M-2000 LIQUID FLASHING®: M-2000 Liquid Flashing is a trowel-grade waterproofing mastic used as a detailing product around penetrations, drains and at corner transitions for horizontal deck and vertical wall installations. M-2000 is a single-component moisture curing elastomer that meets the requirements of ASTM C836-84.

BENTOSEAL®: trowel grade sodium bentonite compound used as a detailing mastic around penetrations and corner transitions for vertical wall SWELLTITE installations.

A-3000WB ADHESIVE®: water-based latex adhesive applied to substrates to promote adhesion of SWELLTITE Membrane. Typical application rate 250-275 sq ft/gallon.

SEAMTAPE®: tape used to seal membrane overlap seams.

AQUADRAIN®: prefabricated drainage composite consisting of a heavy filter fabric adhered to a high-strength plastic drainage core. Aquadrain is available in 4' x 52' rolls.

WATERSTOP-RX®: expanding bentonite based concrete joint strip waterstop designed to replace PVC dumbbell waterstops. Adhered into place with CETSEAL. GF-40SA: UV resistant flashing membrane for grade terminations and thru wall flashing.

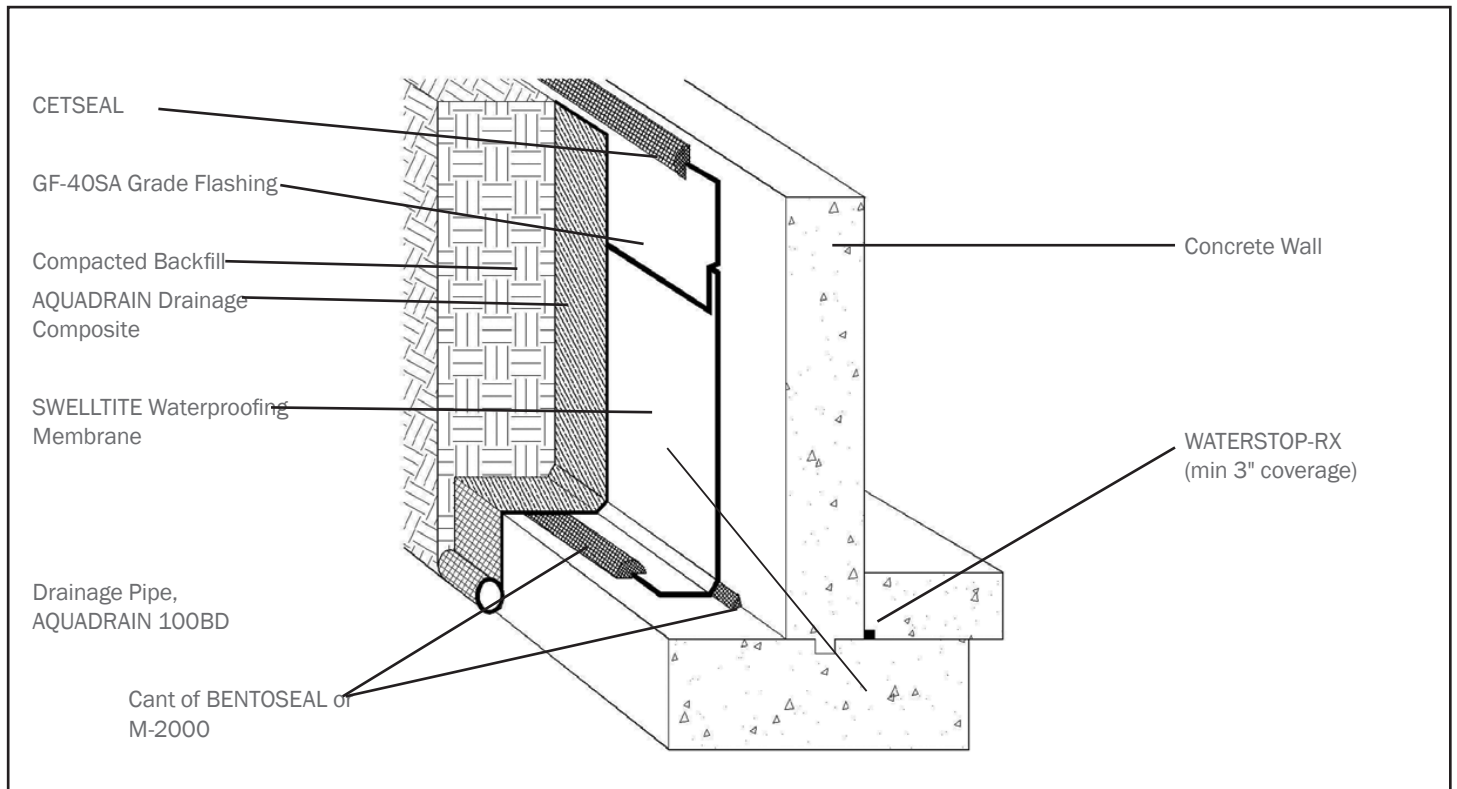

SWELLTITE® COMPOSITE BENTONITE WATERPROOFING SYSTEM

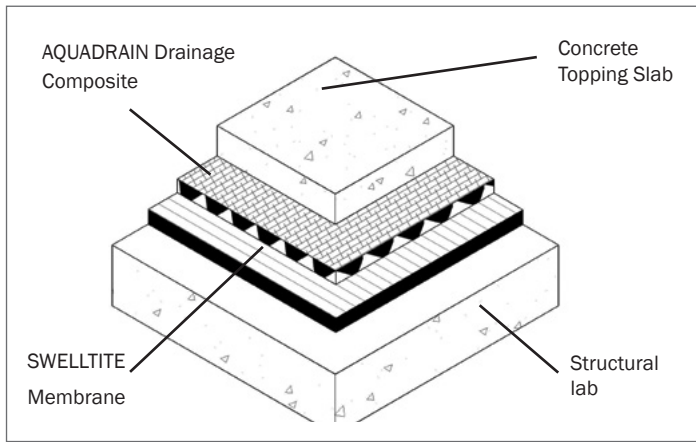

GENERAL APPLICATION DETAILS

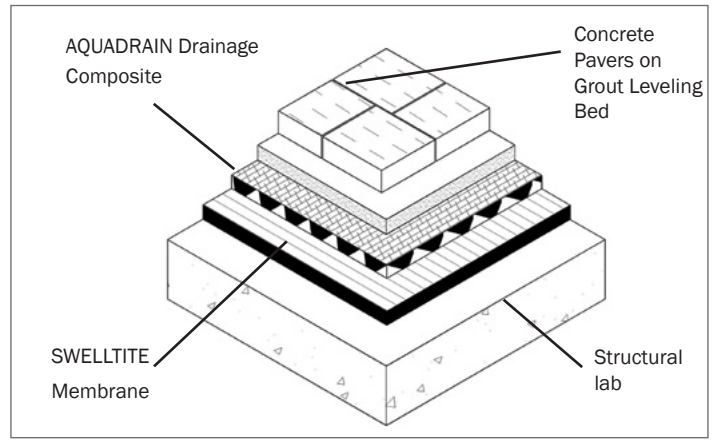

PLAZA DECK - PAVERS OVER GROUT BED

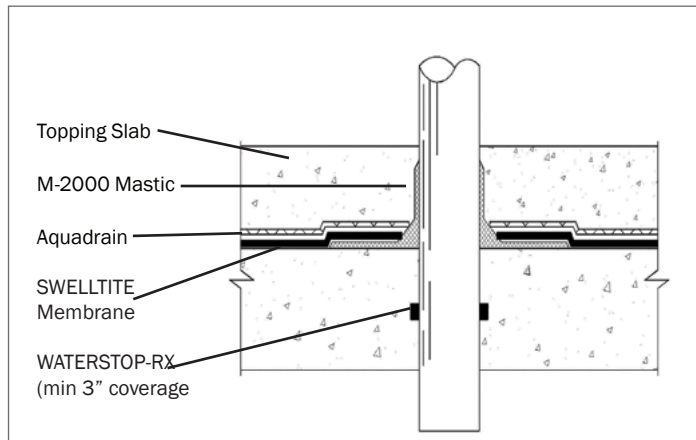

PLAZA DECK PENETRATION DETAIL

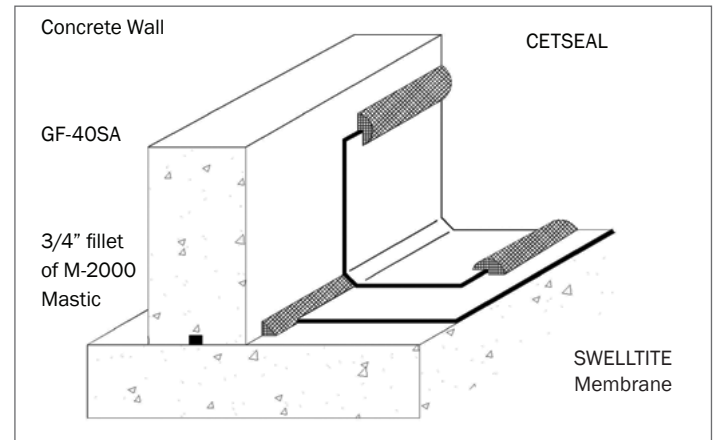

PLAZA DECK TRANSITION DETAIL

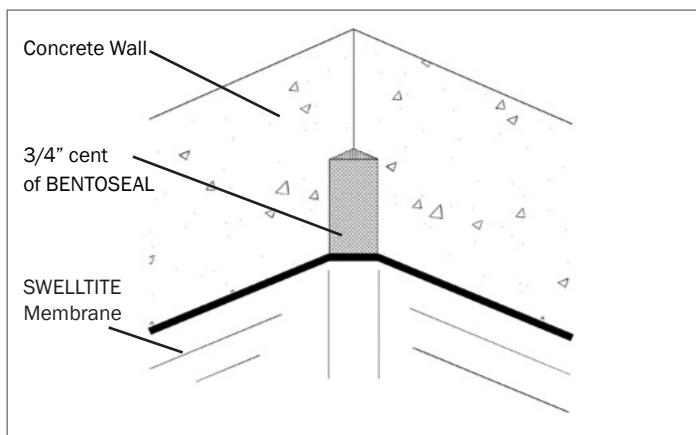

INSIDE CORNER WALL DETAIL

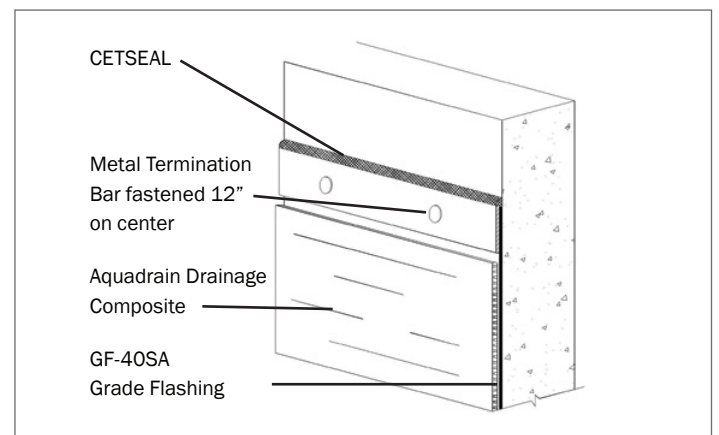

TYPICAL GRADE TERMINATION

North America: 847.851.1800 | 800.527.9948

© 2014 CETCO. IMPORTANT: The information contained herein supersedes all previous printed versions, and is believed to be accurate and reliable. For the most up-to-date information, please visit www.CETCO.com. CETCO accepts no responsibility for the results obtained through application of this product. CETCO reserves the right to update information without notice.

UPDATED: JANUARY 2014

TDS_SWELLTITE_AM_EN_201401_v1

CETCO®

An **AMCOL** Company

www.CETCO.com